

VALMAC SP-2200 Series Positioner is the advanced control device that provides precise control and unparalleled stability in difficult environments

Features

- Precise control performance and high dynamic response
- Simple and easy to set
- Pressure regulator built in to eliminate variations in supply air pressure
- Low air consumption due to piezo electric microvalve
- Output speed controller (output 1, 2) built in as standard
- Input / output signal isolated
- Split range available (4...12 or 12...20mA)
- Simple conversion to direct acting and reverse acting
- Single and double acting available
- No hunting at small actuators
- Limit switches and position transmitter to be built in one unit
- High resistance against shock and vibration
- Modular design to provide good serviceability
- Very compact and light
- Options available:
 - position transmitter (output 4...20mA)
 - limit switches (open and close at any two points)
 - gauge block (two gauges)



SP-2200

Specifications

Input signal	4~20mA
Split range application	4...12 or 12...20mA
Voltage supply	8Vdc...30Vdc
Characteristic	Linear
Stroke	5...65mm (max. up to 150mm)
Input pressure range	1.5...7.0 bar
Air consumption	0.08 m ³ /h at 1.5 bar input pressure
Output pressure range	0...100% of supply air pressure
Media characteristic	Pressurized air or allowed gas, Free of oil and dust
Linearity	< 1.0%
Hysteresis	< 0.5%
Sensitivity	< 0.05%
Operating temperature	-20...+80 (Option -40...+120)
Air piping connection	PT 1/4 or NPT 1/4
Conduit connection	PF 1/2 or NPT 1/2
Body material	Aluminum diecast
Protection standard	IP66
Intrinsic safety	Eex ib IIC T6
Weight	1.2 kg (without gauge block)

Principle of Operation

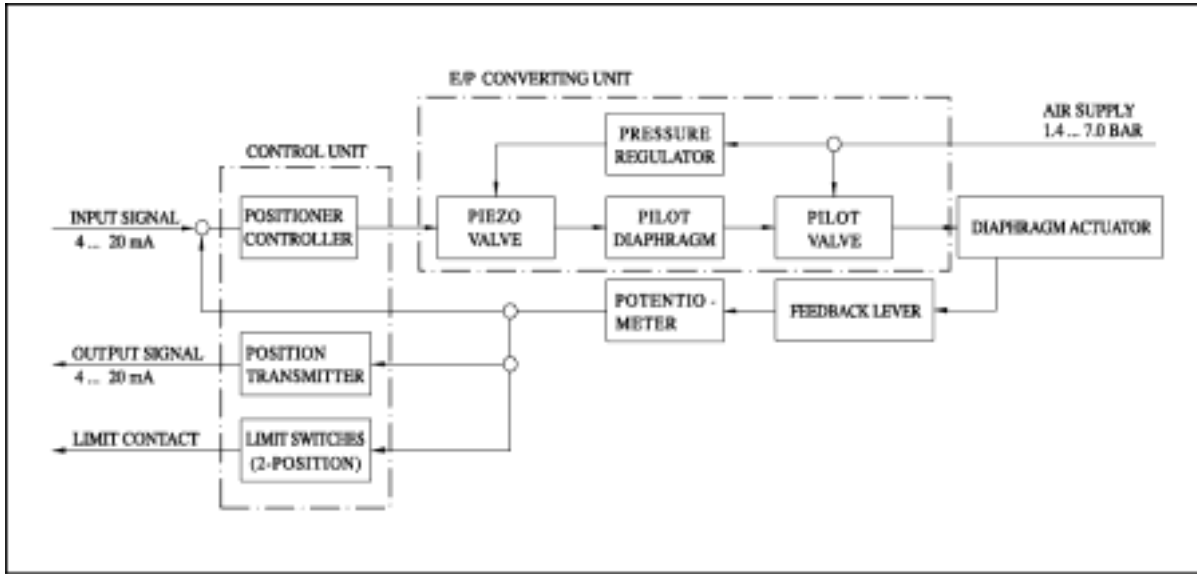

1. Input signal (4...20mA) is supplied into the piezo microvalve by passing through the controller in the control unit
2. Supply air (1.4...7.0bar) is supplied into the piezo microvalve by passing through the pressure regulator in the E/P converting unit
3. Due to the piezo-electric effect, the piezo microvalve generates the pneumatic output signal in proportion to the voltage level coming from the controller
4. Pneumatic output signal is amplified by the pilot diaphragm and operates the spool in the pilot valve
5. Supply air (1.4...7.0bar) is supplied into the diaphragm actuator by the movement of this spool
6. Position feedback from the feedback lever goes into the potentiometer
7. Potentiometer generates the feedback signal, which goes into the controller
8. If the feedback signal equals the input signal, the cylinder actuator stops. If not, the controller supplies the piezo microvalve with the input signal until two signals become equal
9. As options, the built-in position transmitter generates the output signal (4...20mA) and the built-in limit switches generate the contact signals (open and close) with the feedback signal fed by the potentiometer

Air Connections

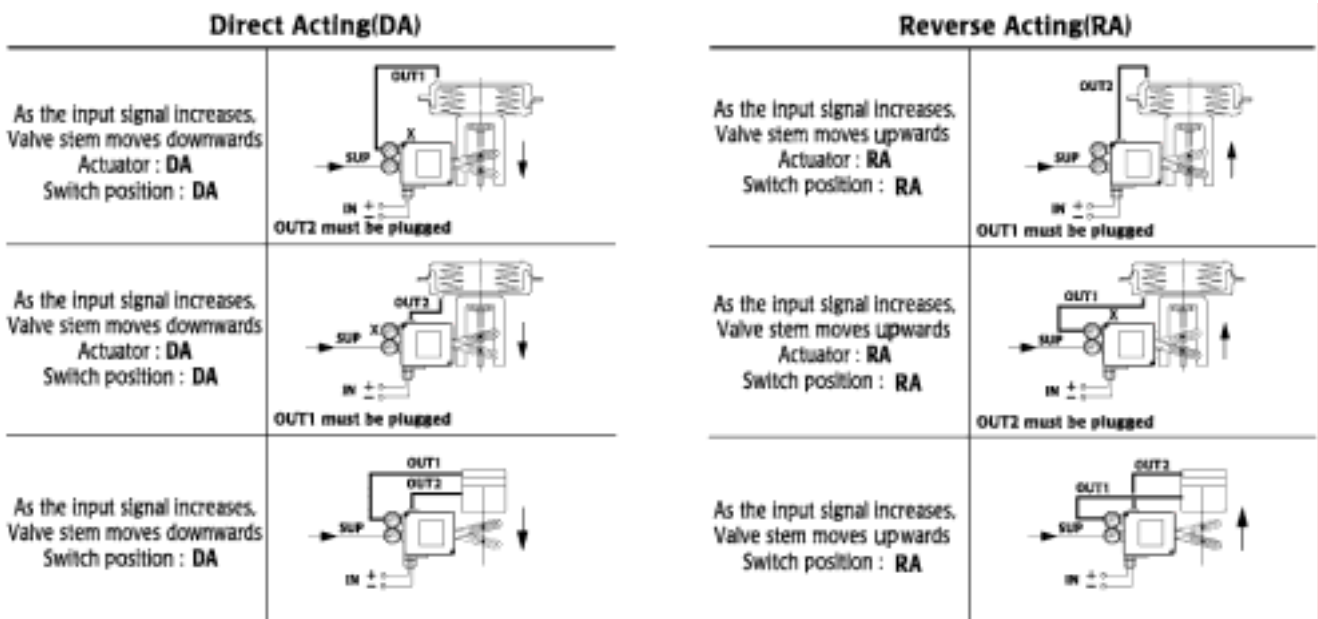

Mounting the Positioner and Attaching the Feedback Lever

Connect the feedback lever to the control valve stem at position where the angle between the valve stem and the feedback lever is 90 degrees as shown to the right below when the input signal is set to 12mA(50%). Be sure that the elimination spring should be installed as shown to the left below according to the actuator type (direct acting or reverse acting)

The stroke range for the best performance should be 5 85mm and the operation angle of the feedback lever should be between Min. 5 degrees and Max. 45 degrees to carry out accuracy and linearity perfectly

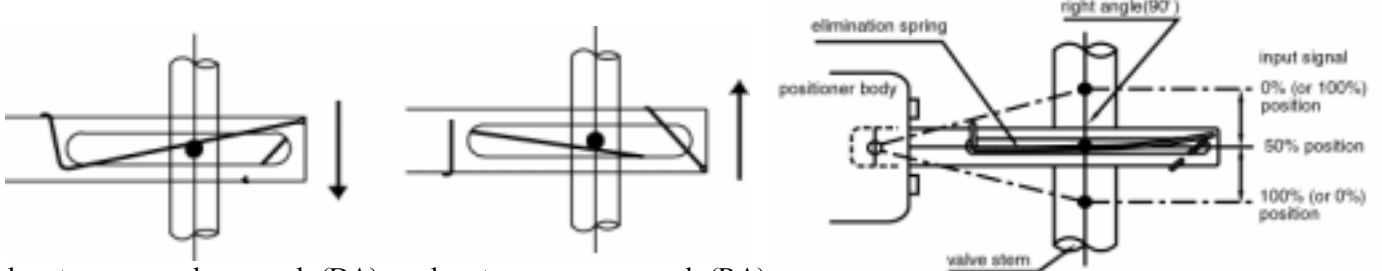

valve stem moves downwards (DA) valve stem moves upwards (RA)

Elimination Spring Installation

Feedback Lever Installation

⚠ Be sure to install the air filter regulator and set the air pressure required for the actuator before supplying air

Electrical Connections

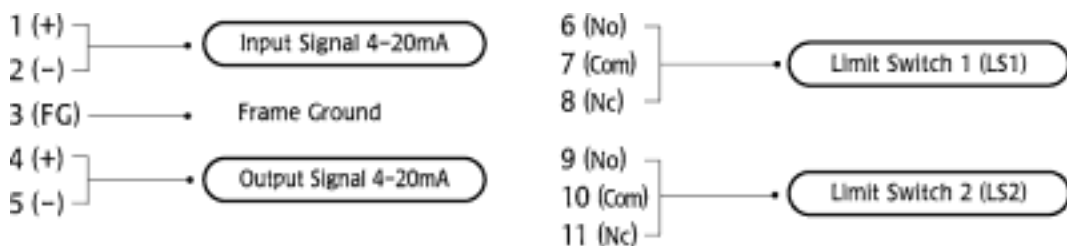
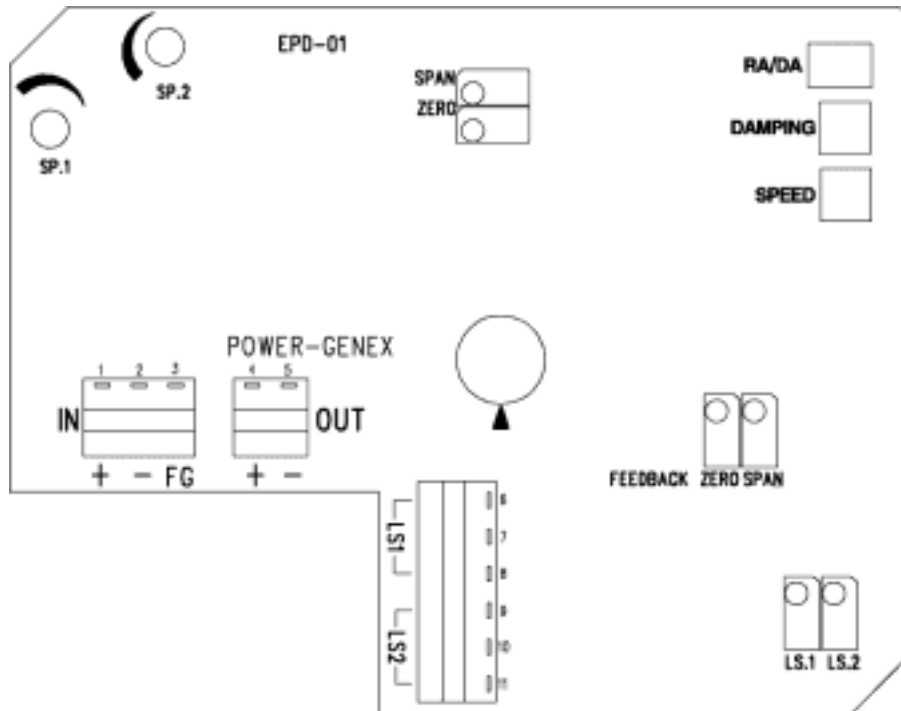

Before Installing and Setting

- 1) Supply air should be the pressurized air or allowed gas. And it is also free of oil and dust
- 2) When opening the positioner cover at humid places, more attention is required. This may cause the serious malfunction of the control board
- 3) When connecting wires of the position transmitter and/or limit switches, eliminate the body blind plug and use the enclosed connector (G16)

Selecting Reverse or Directing Acting

- Left : Reverse acting (RA)
- Right : Direct acting (DA)

! RA is a standard factory setting

Adjusting Span and Zero

When the input signal is set to 4mA, the feedback angle is 0%. And when the input signal is set to 20mA, the feedback angle is 100%



1. Actuator rotates counter clockwise at RA (reverse acting)
2. If you turn the span and zero adjusting screws clockwise, span and zero will increase. If counter clockwise, they will decrease. Please note that if SW 1: DA is selected, the rotation direction of zero and span is counter clockwise
3. If the zero point is exactly set up, you don't have to repeat this adjustment process because, even though the span is re-adjusted, the zero point will not move (fixed)

Control Board of SP-2500 Positioner



Adjusting Damping

Damping is used to adjust sensitivity and hunting. Turning clockwise makes them fast and turning counter clockwise makes them slow. If there happens no hunting at 4...20mA input signal, this is the well-fitted set point



Adjusting Speed

Speed is used to set the response speed of control valve

- Clockwise (CW): fast
- Counter clockwise (CCW): slow



 **Full speed is the standard factory setting**

Lamps

- 1) Green lamp: This will be on if the input signal is supplied. As the input signal increases, it will become brighter
- 2) Red lamp: This will be on if the feedback is connected. As the feedback signal increases, it will become brighter. Note that this will be on once the feedback signal is loaded on the power (15...30VDC)

Adjusting Output Speed Controller (SP1, SP2)

These controllers are used to adjust the supply air volumes of Output 1 and 2

- SP1: to adjust the output 1 speed
- SP2: to adjust the output 2 speed
- Clockwise (CW): low flow
- Counter clockwise (CCW): high flow

 **Full speed is the standard factory setting**

Position Transmitter

Output signal	4...20Ma
Power supply rating	15...30VDC
Recommended power supply	24VDC
Operating temperature	-20...+70
Lode impedance	0...600 Ω
Characteristic	Linear
Linearity	± 0.5% F.S.
Hysteresis	± 0.5% F.S.
Repeatability	± 0.5% F.S.
Adjustment	Zero and span
Rotary angle	50...90° (max. 100°)

- 1) Check the electrical connections correctly. See page 3 for details
- 2) Set the input signal to 4mA, confirm the output signal, and fix the zero screw at 4mA
- 3) Set the input signal to 20mA, confirm the output signal, and fix the span screw at 20mA. Please keep it in mind that you don't have to repeat this adjustment process because the zero point is fixed, even though the span is moved.
- 4) Check the input signal and the output signal once again one by one as follows

- Input signal: 4 → 8 → 12 → 16 → 20mA
- Output signal: 4 → 8 → 12 → 16 → 20mA

 **Be sure to set the positioner properly in order to get the correct outputs**

Limit Switches (LS1, LS2)

Rated power	Max. 1W
Switching voltage	Max. 100VDC
Switching current	Max. 0.01A
Carry current	0.5A
Breakdown voltage	Min. 150VDC
Operating temperature	-20...+70
Isolation coil / contact	Min. 4.0KVDC
Insulation coil / contact	Min. 10 ¹⁰ Ω

- 1) Check the electrical connections. See page 3 for details
- 2) Select NO or NC, turn LS1 or LS2 screw, and set the contact points
- 3) Lamps beside limit switch adjusting screws will be on when the contact points reach open and close positions

Troubleshooting Tips

Problem	Solution
Green lamp is off	→ Check the input signal connections. See page 3
Red lamp is off	→ Check the output signal connections. See page 3 → Check whether the power (15...30VDC) is supplied or not
Actuator is suffering from the hunting	→ Eliminate the hunting by turning the damping screw counter clockwise at 50% position → Check whether the positioner feedback shaft is exactly inserted into the actuator top pinion (output shaft)
The response speed of the actuator is too fast	→ Adjust the speed by turning the output speed controller (SP1, SP2)

Order Information

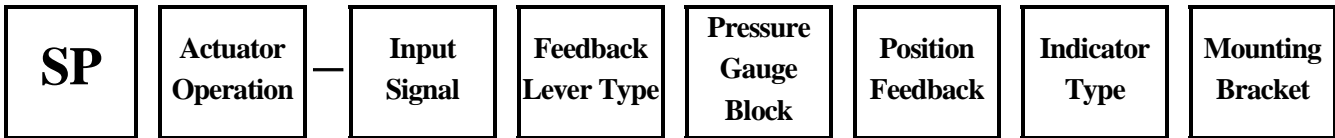

<u>Description</u>	<u>Order Code</u>	<u>Description</u>	<u>Order Code</u>
Actuator Operation: - Linear type - Rotary type	2200 2300	Position Feedback:	N: none O: position transmitter (output signal 4...20mA) L: 2-limit switches M: O+L
Feedback Lever: - Linear type - Rotary type	A: stroke (5...65mm) B: stroke (10...85mm) C: stroke (up to 150mm) A: NAMUR shaft	Indicator Type: (Only for SP-2200)	F: flat type (standard) D: dome type
Pressure Gauge Block:	N: none 1: 6 bar (90psi) 2: 10 bar (150psi)	Mounting Bracket: (Only for 2300)	N: none 1: 80 × 30 × 20 (H) 2: 80 × 30 × 30 (H) 3: 130 × 30 × 30 (H)

Dimensions

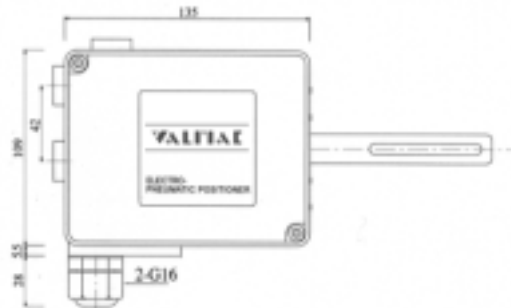
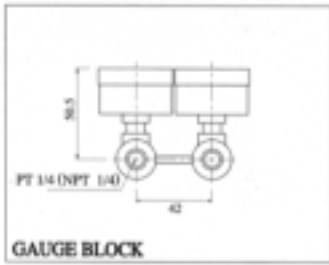

* Feedback Lever Length(mm) : L
A Type : 123
B Type : 185
C Type : 242

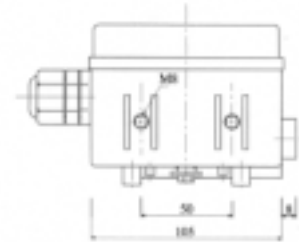
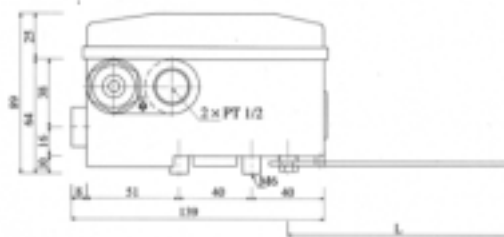
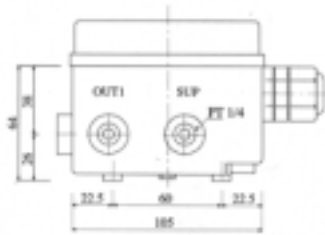

SEO JEON VALMAC Co., Ltd.

691, ORYU-DONG
SEO-GU. INCHEON. KOREA

Tel: +82-32-565-3121

Fax: +82-32-565-3124

E-mail: valmac@valmac.co.kr

Website: <http://www.valmac.co.kr>