

Description of Device

VALMAC Posi-Zest SP-2100 Series Electro-Pneumatic Rotary Positioner is the advanced control device for a rotary control valve that provides unparalleled stability in difficult environments.

- Easy Maintenance
- Precise Calibration with simple SPAN and ZERO adjustments
- Simple Conversion to Direct Acting or Reverse Acting
- 1/2 Spilt Range Available by simple adjustments without changing parts
- Simple Structure for feedback connection
- Corrosion-Resistant Aluminum Die Casting Body
- Sensitive and Correct Response for high performance
- Economical Energy Saving
- Extremely Vibration Resistant Design
- Stainless Steel Gauges Standard
- A Restricted Pilot Valve Orifice Kit for small actuators included
- Optional Built-in Limit Switches or 4-20mA Position Transmitter for feedback
- Optional Directly-Mountable Positioner guaranteeing more outstanding stability

Part Number System

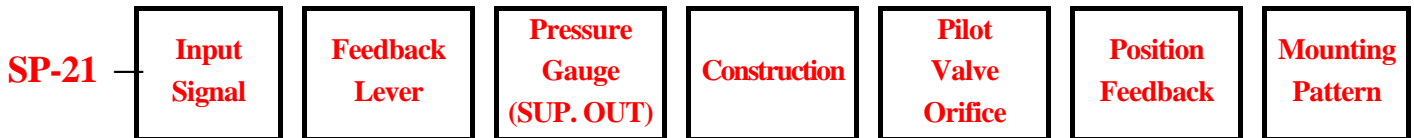

<u>Description</u>	<u>Code</u>	<u>Description</u>	<u>Code</u>
Input Signal: 4~20mA	00: Standard	Pilot Valve Orifice:	S: standard actuator (actuator volume over 180 cm ³) M: small actuator (standard) (actuator volume 90~180 cm ³)
Feedback Lever:	A: M6 X 40L (standard) B: M8 X 40L C: M6 X 60L D: M8 X 60L	Position Feedback:	N: none (standard) O: position transmitter (output signal 4~20mA) L: 2 SPDT limit switches (open and close)
Pressure Gauge:	1: 4kgf/cm ² (60psi) 2: 6kgf/cm ² (80psi) 3: 10kgf/cm ² (150psi, standard)	Mounting Pattern:	F: standard mounting (fork lever type, standard) D: direct mounting (namur type)
Construction:	W: with a terminal box (explosion proof, standard) N: without a terminal box (weatherproof)		

Specification

	SP-2100	
	Rotary Type (Cam Feed back)	
	Single	Double
Input Signal	4~20mA DC (Note. 1)	
Input Resistance	235±15	
Air Supply Pressure	Max. 7.0kgf/cm ² (100psi)	
Standard Stroke	60 ° ~ 100° (Note. 2)	
Air Piping Connection	PT 1/4 (NPT 1/4)	
Conduit Connection	PF 1/2 (NPT 1/2)	
Explosion-Proof Classification	Exmd BT6, Exmd C(H2)T6, IP66, Exia BT6	
Ambient Temperature	-20~70	
Pressure Gauge	Stainless Steel	
Output Characteristics	Linear	
Linearity	Within ± 1.5 % F.S	
Sensitivity	Within 0.5 % F.S	
Hysteresis	Within 1.0% F.S	
Repeatability	Within ± 0.5 % F.S	
Air Consumption	5 LPM (Sup. 1.4kgf/cm ²)	
Flow Capacity	80 LPM (Sup. 1.4kgf/cm ²)	
Material	Aluminum Die Casting Body	
Weight	2.9 kg (with a terminal box)	

Note: 1) 1/2 spilt range can be adjusted

2) Stroke can be adjusted to 0 ° ~ 60° or 0 ° ~ 100°

Principle of Operation

As the signal current from the controller increases, the plate spring of the torque motor works as a pivot. As the armature receives the rotary torque in the counter-clockwise direction, the counter-weight is pushed to the left, the clearance between the nozzle and the flapper will increase, and the back pressure of the nozzle will decrease. As a result, the exhaust valve of the pilot valve moves to the right, and the output pressure of OUT1 increases (as OUT 2 decreases) to move the cylinder actuator.

The movement of the actuator in turn rotates the feedback shaft, and the feedback spring lengthens or shortens by the movement of the feedback cam connected to the feedback shaft. The actuator stays in the position where the spring force is balanced with the force generated by the input current in the torque

motor. The compensation spring is for direct feedback of the motion of the exhaust valve and is connected to the counter weight to enhance the stability of the loop. The zero point is adjusted by changing the zero adjustment spring tension.

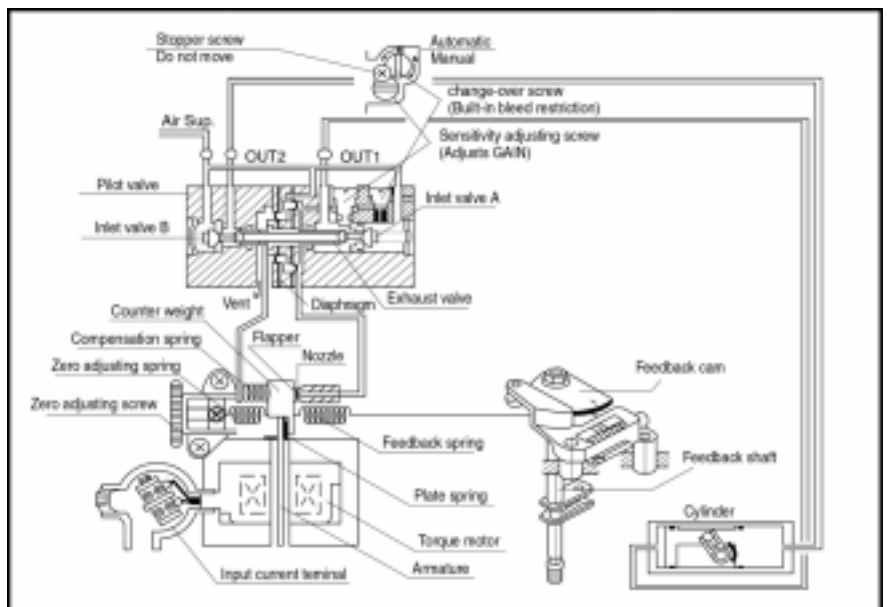

Mounting the Positioner and Attaching the Feedback Lever

- Standard Mounting (Fork Lever Type)

Mount the bracket to the actuator. The brackets have been designed for actuators with the 80 X 30mm NAMUR accessory pattern. For the 130 X 30mm pattern, the block type bracket is available.



Standard Bracket (80 X 30)



Block Type Bracket (130 X 30)

Mount the fork lever "B" to the actuator and thread it into the actuator first before mounting the positioner and the bracket to the actuator.

Once the bracket has been mounted to the actuator, mount the positioner to the bracket with the bolts (2-M8 or 3-M8). Be sure that the feedback lever (feedback lever shaft "A" + fork lever "B") is in perfect alignment with a rotary actuator output shaft. The spring pin of the feedback lever shaft "A" acts as a guide and should be placed in the orifice of the fork lever "B". Please note that linearity and hysteresis will suffer if these alignment and placement are not correct.

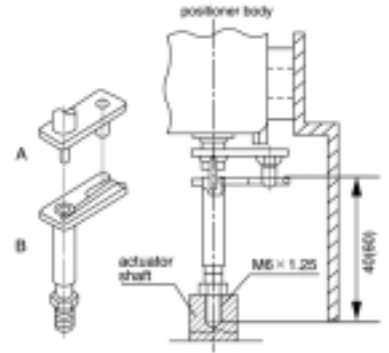

Standard Mounting (Fork Lever Type)

- Direct Mounting (NAMUR Type, see the right picture)



NAMUR Type Bracket (80 X 30 X 20)



NAMUR Type Bracket (130 X 30 X 30)

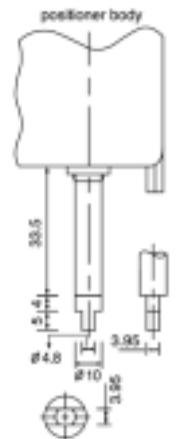

Direct Mounting (NAMUR Type)

Cam and Indicator Adjustment

Loosen the flange nut on the cam. Match the part of the cam with "0" marked on it with the center of bearing as shown to the right. The span adjusting arm unit should now be aligned.

Tighten the flange nut of the cam after setting the cam.

After cam installation, proceed to adjust zero and span. Once this is complete, secure the indicator with the bolt (M6) to the feedback shaft according to the actuator type (RA or DA) as shown below. The position for the indicator should be arranged in the scale (0-90 degrees) shown on the cover.

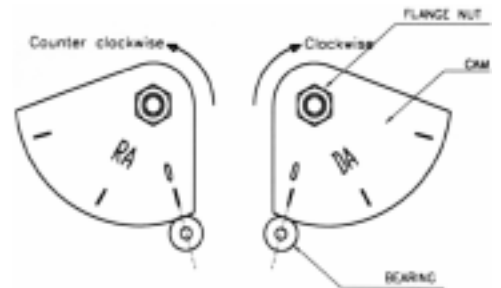

⚠ Be sure that RA (reverse acting) is the standard factory setting.

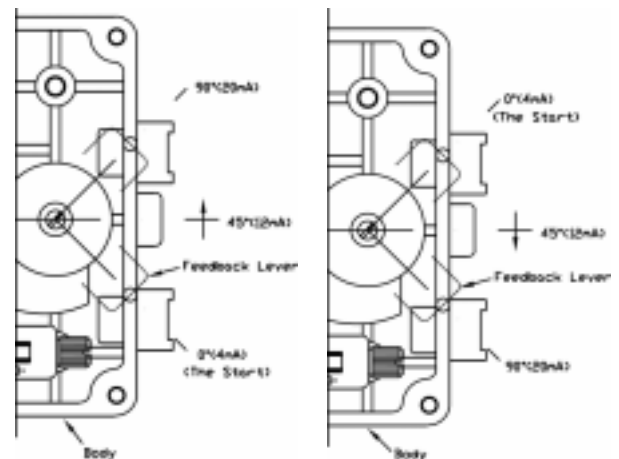

[RA]

[DA]

Span and Zero Adjustment

Check all air connections. See page 5 for details.

Set input signal to 4mA (24 VDC) while positioner is at the 0% or stroke starting point. Turn the zero adjustment knob clockwise or counter clockwise to set the zero position.

Check the stroke of actuator by setting the signal to 20mA at 24 VDC. If the stroke does not meet 100%, turn the span adjustment screw clockwise or counter clockwise until 100% is reached.

Set input signal back to 4mA (24 VDC) and adjust the zero adjustment screw until starting point is reached.

Repeat the process until the desired set point is reached.

Pilot Valve Seat Adjuster

The seat adjuster (sensitivity adjusting screw) located on the pilot valve is used to adjust the positioner for double-acting actuators. Normally, no adjustment is required.

When the sensitivity is not optimal, rotate this screw clockwise. If there is hunting, rotate the screw counterclockwise. For smaller actuators, it might be necessary to insert the small pilot valve orifice inserts if adjusting the seat does not improve performance.

Auto / Manual Operation

For manual operation using an external air regulator, set the Auto / Manual switch located on the pilot valve to M. This will bypass the 4~20mA input signal.

Internal View of SP-2100 E/P Rotary Positioner

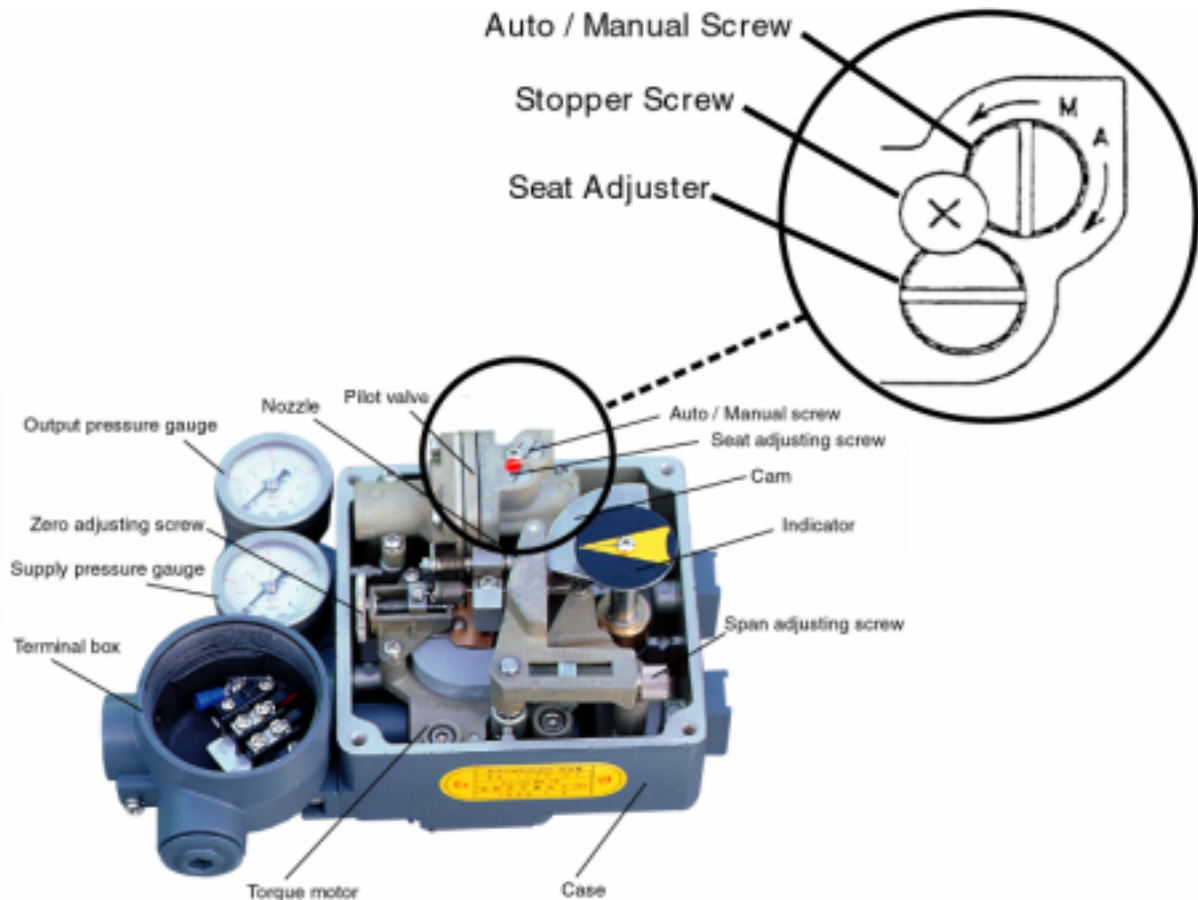



*Installation and Operating Instructions
Electro-Pneumatic Rotary Positioner*

Air Connections

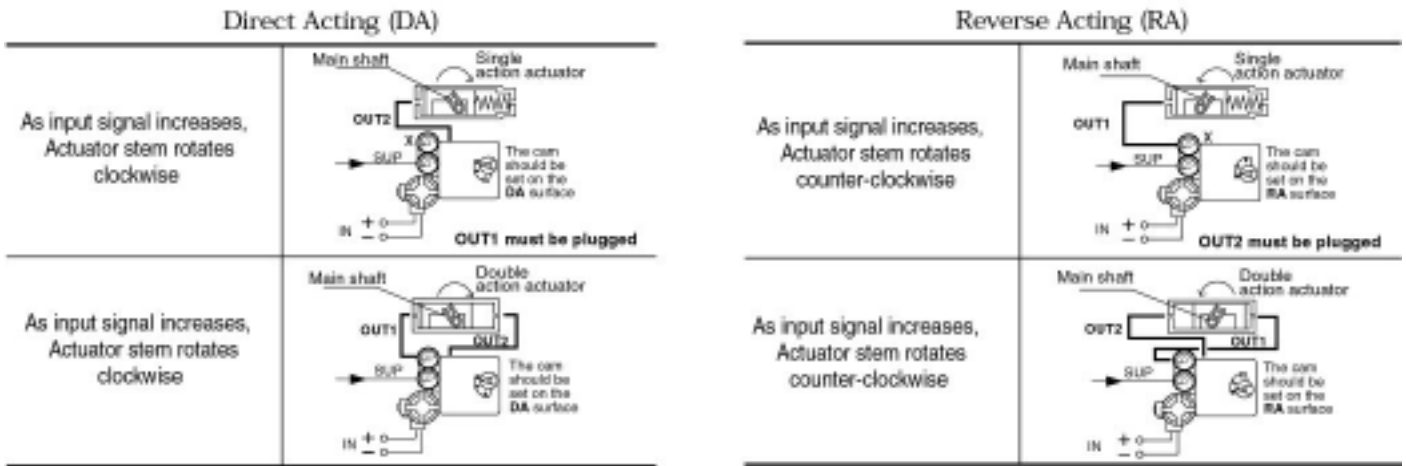

Wire Diagrams

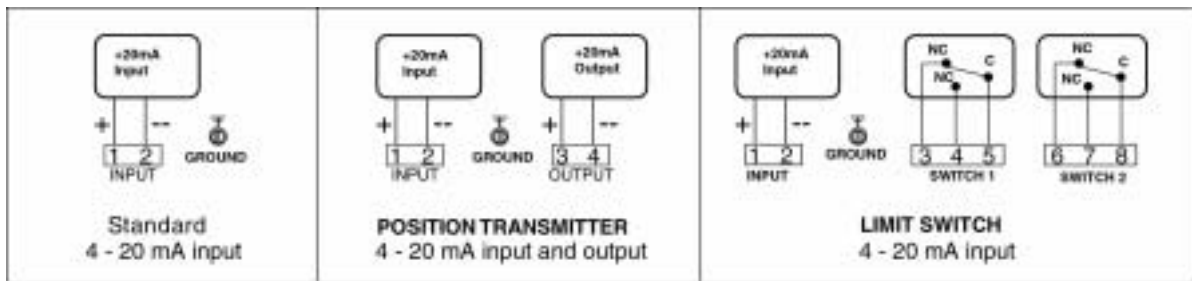

CAUTION: Always check that the electrical load is within the range stated on the nameplate. Failure to remain within electrical ratings may result in damage to or premature failure of the electrical switches, sensors or transmitter electronics.

Specifications – Current Output

Power Supply Rating:	15 – 28 VDC loop power
Recommended Power Supply:	24VDC
Output Signal:	4 – 20 mA
Operating Temperature:	-20° to 70
Load Impedance:	0 – 600 ohms
Max. Output:	35 mA DC
Linearity:	± 1.0 %
Hysteresis:	1.0% of full scale
Repeatability:	± 0.5 % of full scale
Adjustment:	Zero and Span in Terminal Box

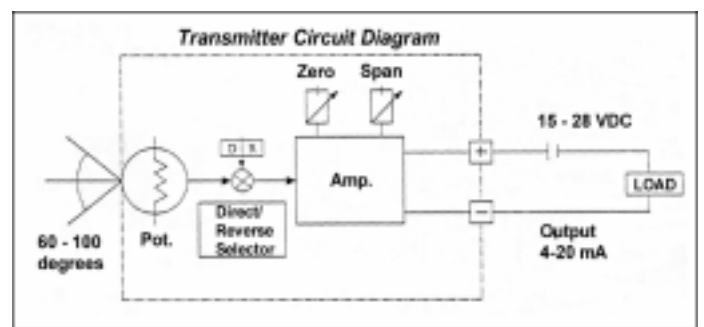

Specifications – Limit Switches

Contacts:	SPDT Form C
AC Rating:	5A – 125 VAC / 3A – 250 VAC
DC Rating:	1A – 24 VDC
Adjustment:	cams with set screws

Optional Restricted Pilot Valve Orifice

⚠ WARNING: Before removing the pilot valve, be sure to disconnect the positioner from the signal and compressed air source.

For improved control using smaller actuators, a restricted pilot valve orifice kit is included with the positioner. To install, the pilot valve must be removed from the positioner. Remove the four screws holding the pilot to the positioner body. As you remove the valve, be sure to hold the compensation spring (see page 2) in place. Flip the valve so the bottom faces you. Remove the o-rings from the *out 1* and *out 2* ports (as shown in the diagram at right). Place the orifice plates in their place with new o-rings above them, and re-install the pilot valve, making sure the compensation spring is back in place. The positioner is now set up for smaller actuators.

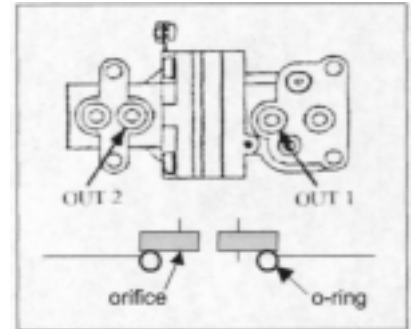

Troubleshooting Tips

Hunting

- * If your actuator is small, install orifice restrictions in ports 1 and 2 of the pilot valve. Then the control valve moves slow.
- * The nozzle might be clogged. Take the metal wire located in the positioner cover and clean the nozzle.

- * Check Zero and Span adjustments
- * Loose feedback lever – tighten feedback lever

Poor Linearity

- * Air supply might be unstable- check or install a pressure regulator.

Poor Hysteresis

- * Loose mounting of the actuator to the positioner – tighten the mounting bracket.
- * Adjust the seat, using the seat adjuster (double acting actuators only)

Dimensions

